

Article datasheet

## Batteryholder for 1x "9V" cell Aluminium natural,PCB mounting

Article-No.: 015.91.837

Manufacturer: Keystone Electronics

Manufacturer article-no.: 1291



Image may be similar

Battery Type: 9V-Block  
 Material: Aluminum ENAW-5754 / AlMg3, lead-free  
 Material Group: Aluminum  
 Model: PCB Mounting Connection  
 No. Cells: 1  
 Weight: 8.7g  
 Conformities:



You can find all information on the web on our article detail page

[Batteryholder for 1x "9V" cell Aluminium natural,PCB mounting](#)

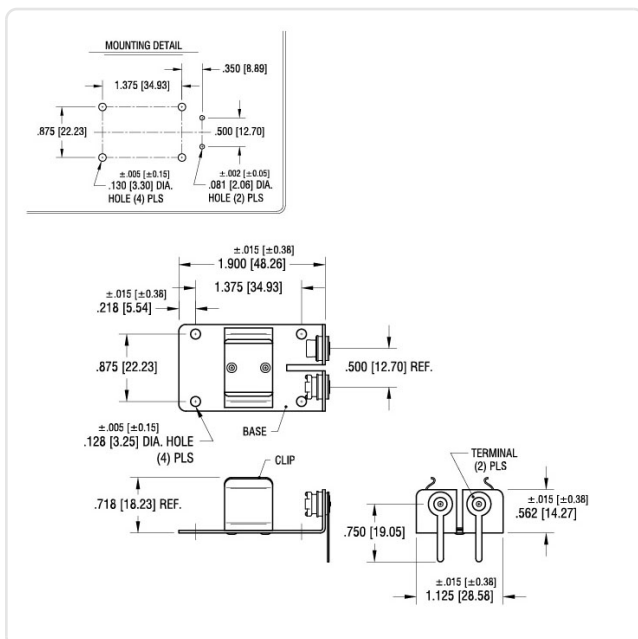

Would you like individual advice?

We look forward to your email to [products@ettinger.de](mailto:products@ettinger.de).

Subject to change and errors.