

Article datasheet

Horizontal 9V PCB Snap-On (Male) Steel tinned - nickel-plated contacts

Article-No.: 015.84.956

Manufacturer: Keystone Electronics

Manufacturer article-no.: 593

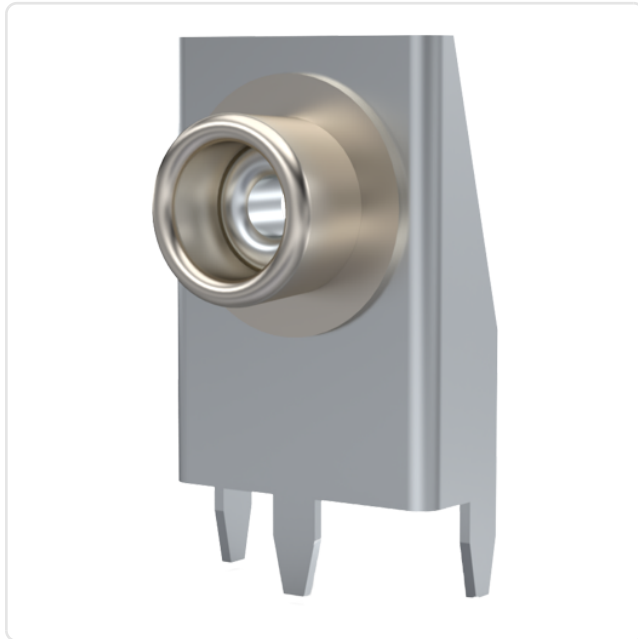

Image may be similar

Battery Type: 9V-Block
 Finish: Tin-Plated
 Material: Steel
 Material Group: NULL
 Width [mm]: 10.4
 Weight: 0.96g
 Conformities:



You can find all information on the web on our article detail page

[Horizontal 9V PCB Snap-On \(Male\) Steel tinned - nickel-plated contacts](#)

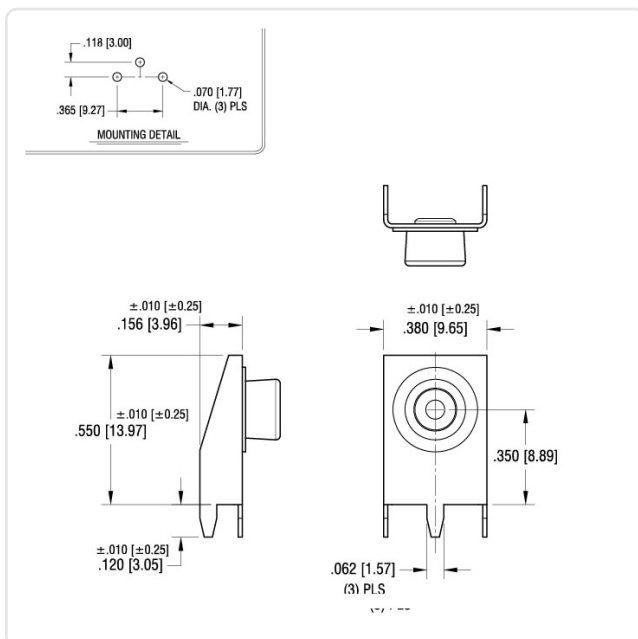

Would you like individual advice?

We look forward to your email to products@ettinger.de.

Subject to change and errors.